

PRIMARY LOGO

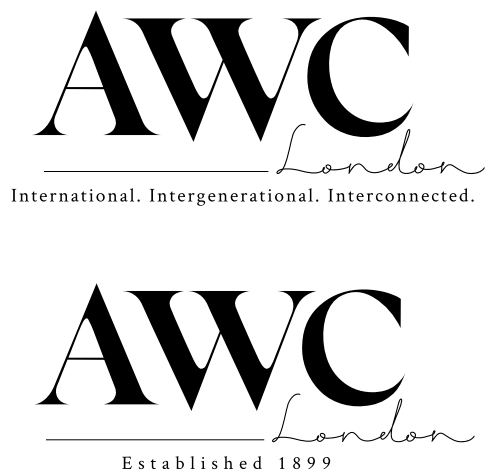

SECONDARY MARK



COLOUR PALETTE

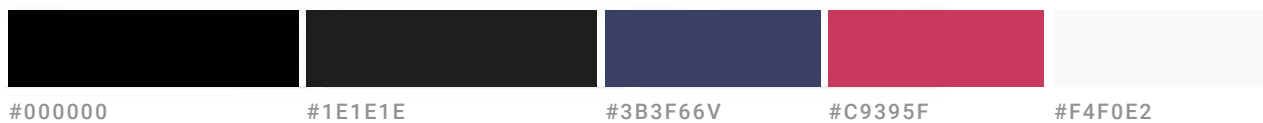

#000000

#1E1E1E

#3B3F66V

#C9395F

#F4F0E2

PRIMARY TYPEFACE

AaBbCc01234

Georgia

abcdefghijklmnopqrstuvwxyz
ABCDEFGHIJKLMNOPQRSTUVWXYZ
WXYZ

WEB COPY TYPEFACE

AaBbCc01234

Helvetica

SECONDARY TYPEFACE

AbBbCc01234

Beyond Infinity

abcdefghijklmnopqrstuvwxyz
ABCDEFGHIJKLMNOPQRSTUVWXYZ
WXYZ

LOGO USAGE

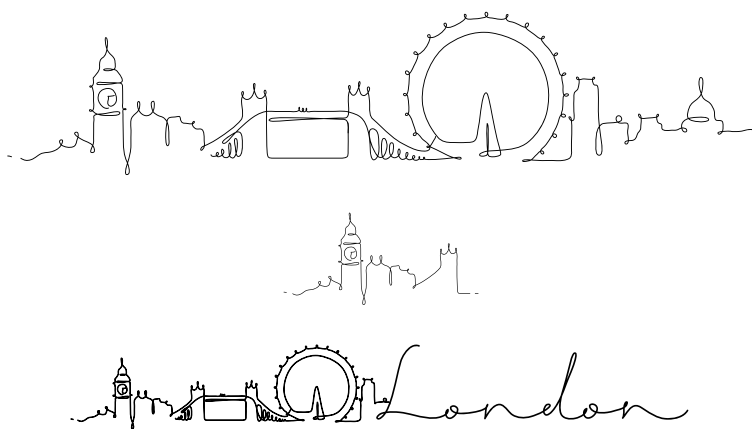
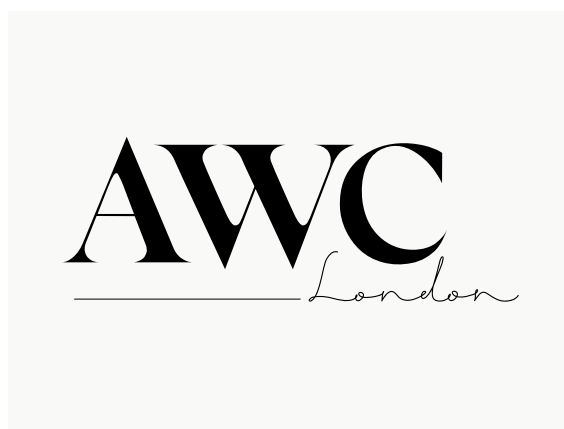

INCORRECT LOGO USAGE

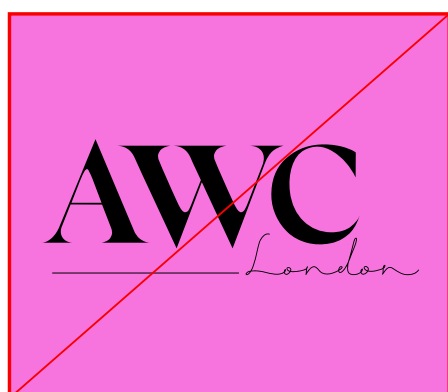

DO NOT use a coloured background that is not in line with brand colours.

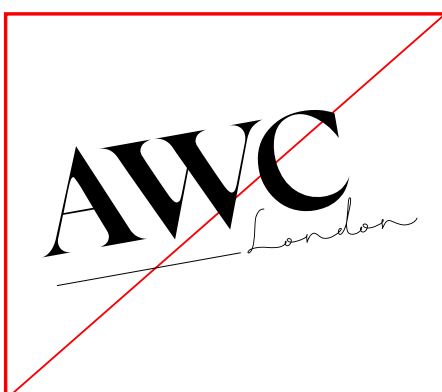

DO NOT place the logo on an angle



DO NOT place the logo on patterned background



DO NOT change the logo colours outside of the brand colours,

Homepage

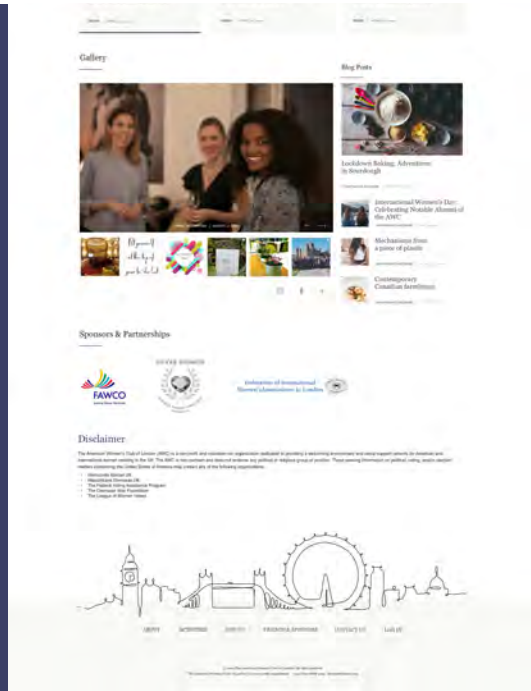
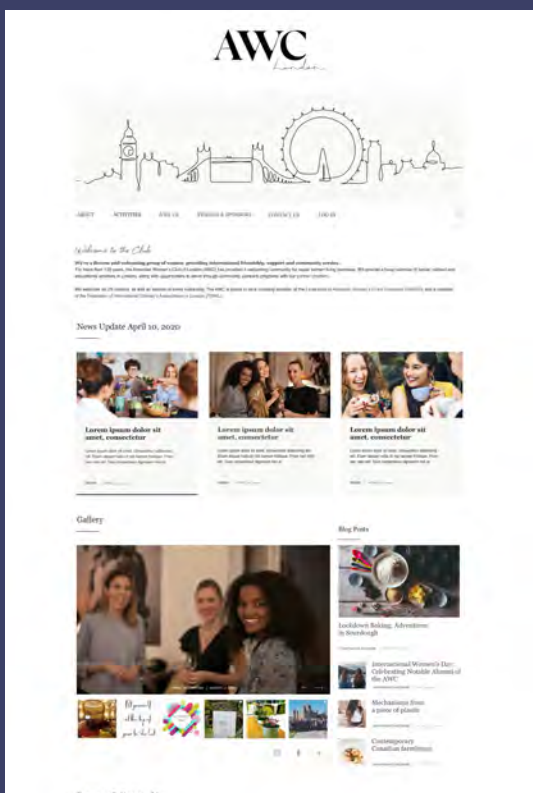

Blog page

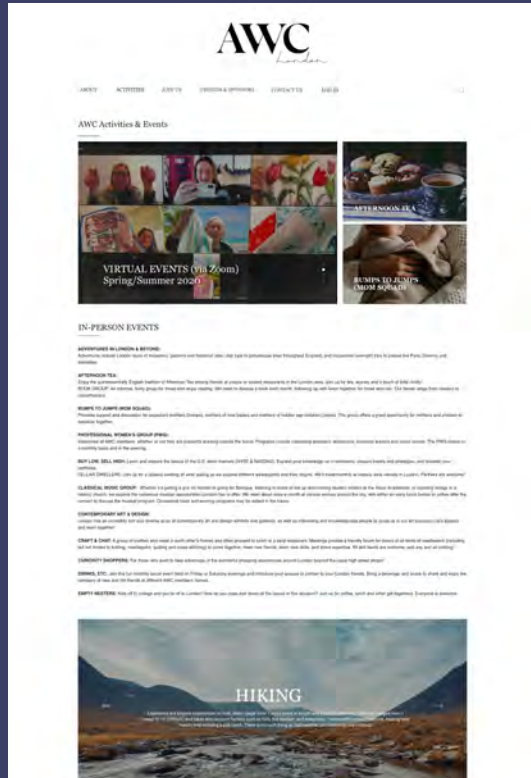

Events Page



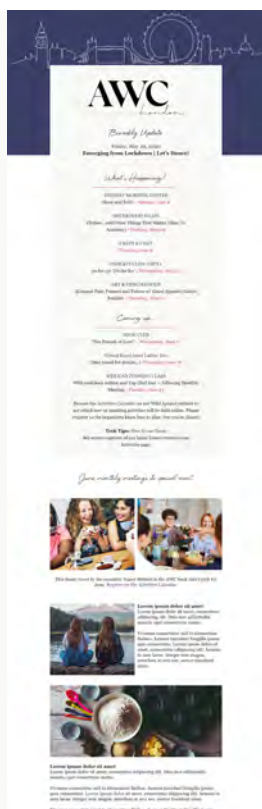

Homepage

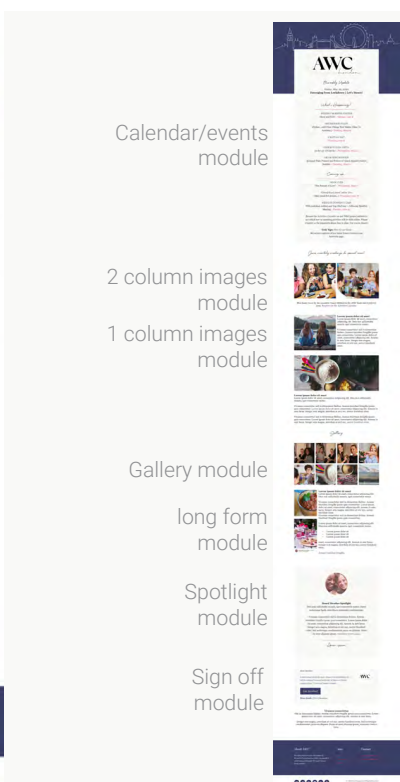

Full image module

Footer

BANNER ADS

Banner ads look and feel, can be animated up to 4 frames.
 (Copy is a placeholder and is there for character count)

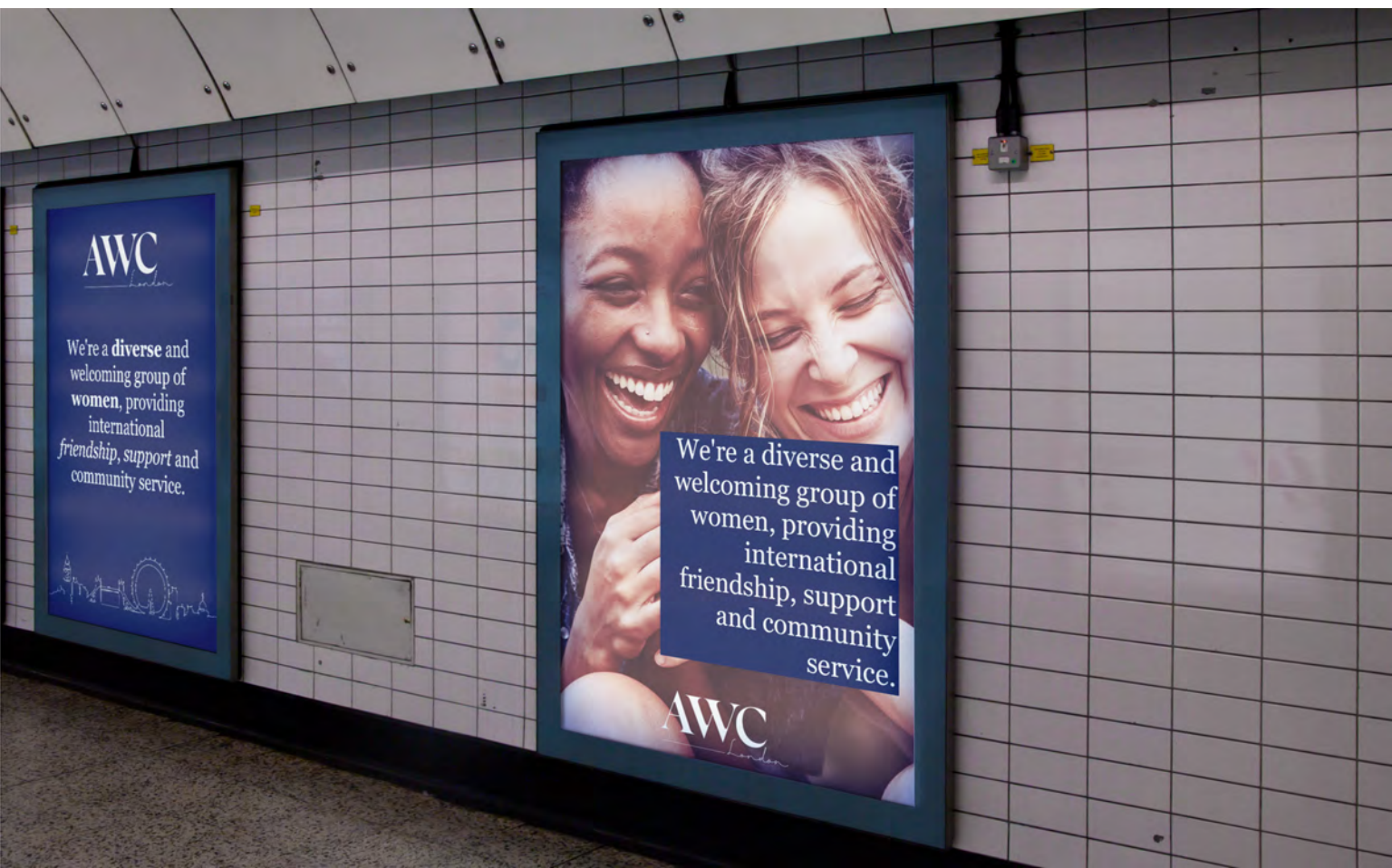
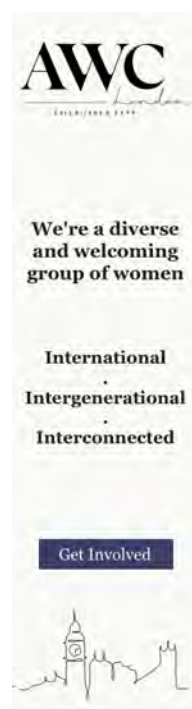

LOGO ICON

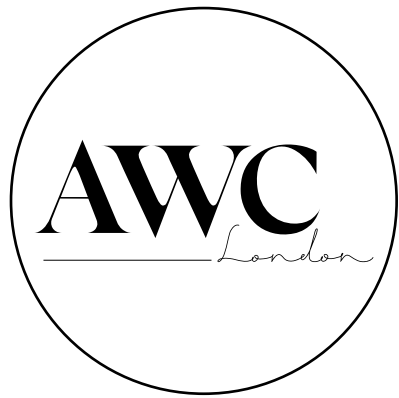
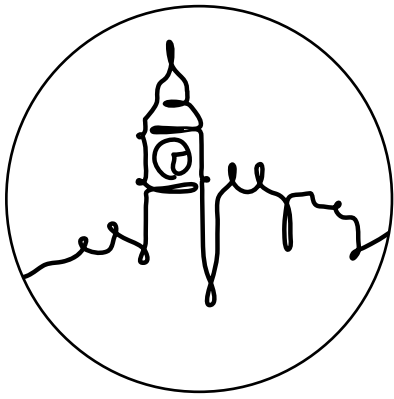

SKYLINE

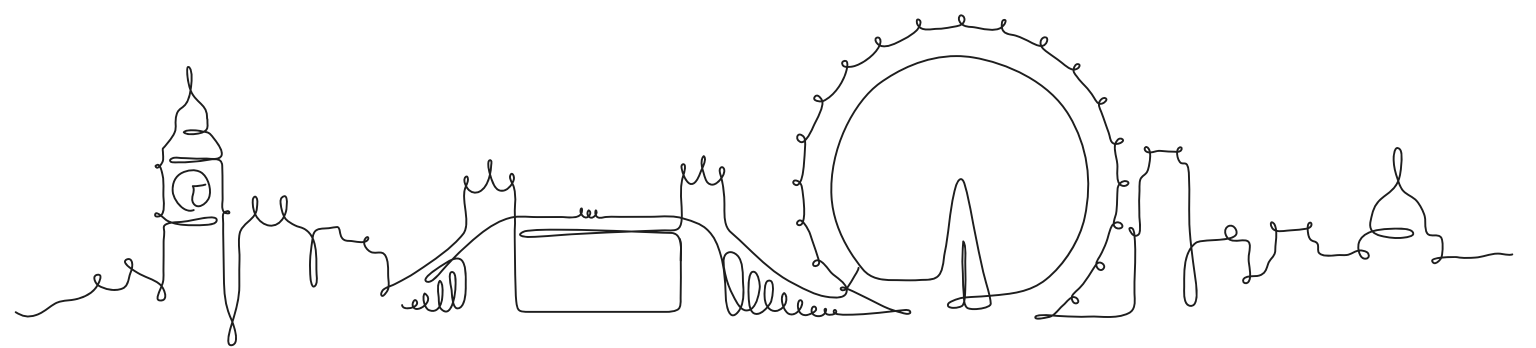
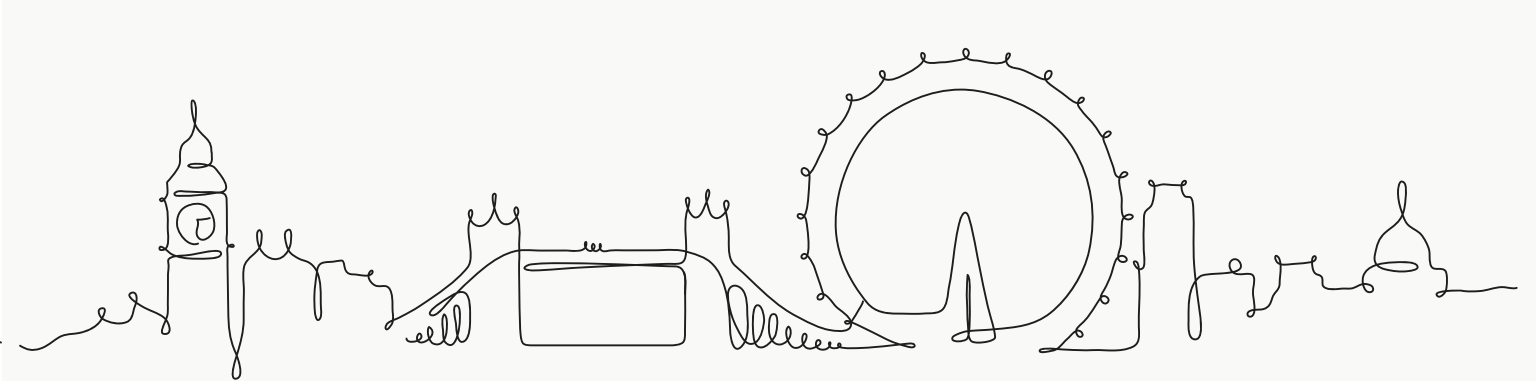
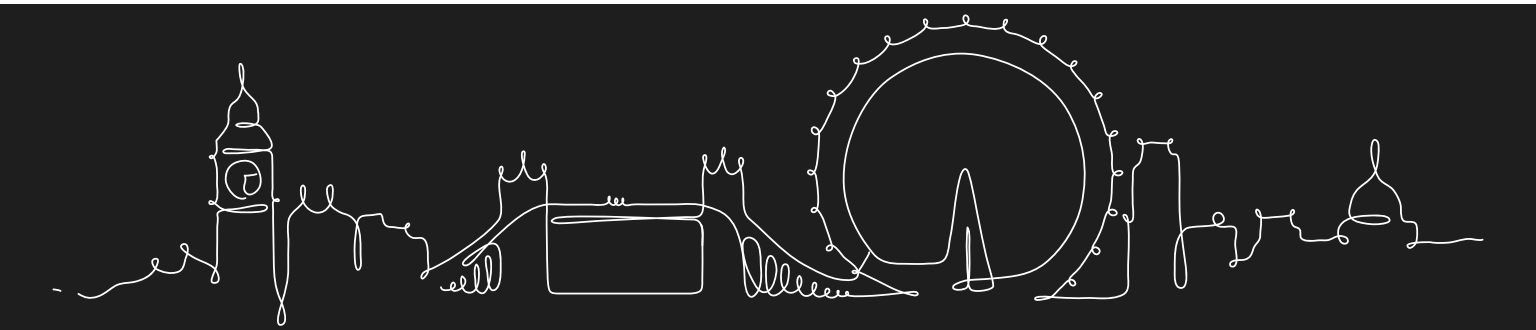

WATERMARK

